



# **AutoHoot Instruction Manual**

## **Contents**

- 1 Introduction
  - 2 Installation
  - 3 Quick Set-up RR26
  - 4 Switch settings
  - 5 Start Sequences
  - 6 Programming User Sequences
  - 7 User sequence commands
  - 8 User sequence example
  - 9 Power indication
  - 10 Specification
- User Sequence Programming Table



## 1. Introduction

This Instruction Manual applies to AutoHoots shipped from the manufacturer after February 2001 with issue 2.0 and 2.1 software. If you wish to have an older AutoHoot upgraded please contact the manufacturer. The main changes in the software are the provision of a new RR26 sequence with options for extended warning signal times and two user programmable sequences. Issue 2.1 introduced some additional commands for use when programming user sequences.

Any complexity inferred by the length of these instructions is due to the large number of starting sequences in use and AutoHoots flexibility at coping with them. The complexity should not be evident to the race officer starting a race, as once set up for the starting sequence used by your club, AutoHoot is extremely simple and intuitive to use (see picture below). The standardisation brought about by the introduction of the 2001 racing rules means that in most cases setting up AutoHoot will be covered in “Quick set-up for RR26” section of this manual and requires little more than selecting the warning signal and how long the horn should sound.

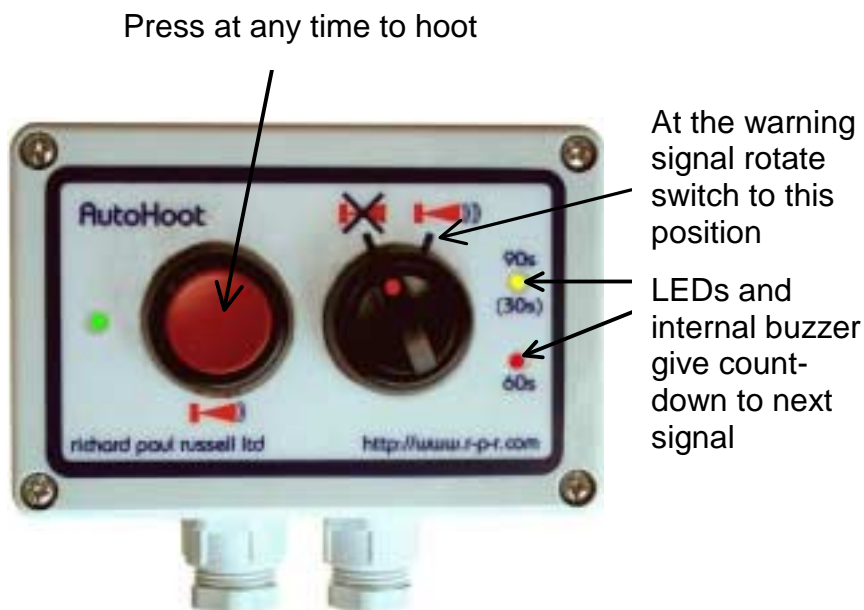



## 2. Installation

AutoHoot is an electronic control unit. A power source and horn must be provided. A small 12-volt car battery or if fitted on a committee boat the boats main battery is ideal. For most dinghy clubs on restricted water the type of low cost car horn that can be purchased from your local car accessory shop is suitable. If you are starting large fleets on open water then a large truck horn or marine horn may be better.

Access to the inside of the unit for wiring or adjusting the settings is gained by releasing the four corner spring loaded catches with a screwdriver. These require a quarter turn anticlockwise.

Connections are to two green terminal blocks either side of the fuse. The left-hand block is for connection to the battery and the right-hand block is for connection to the horn. The individual connections are marked on the printed circuit board. The terminals will accommodate cable with up to 2.5mm square conductors. Connection to the battery should be via a battery isolation switch if AutoHoot is to be permanently installed. Car horns can require high peak currents (15 to 20A), so long cable runs should be avoided. If higher currents are required AutoHoot can be used to drive a suitable relay. When installing AutoHoot be careful not to strain the ribbon cable connection between the circuit board and the front. This may be unplugged from the circuit board if necessary.

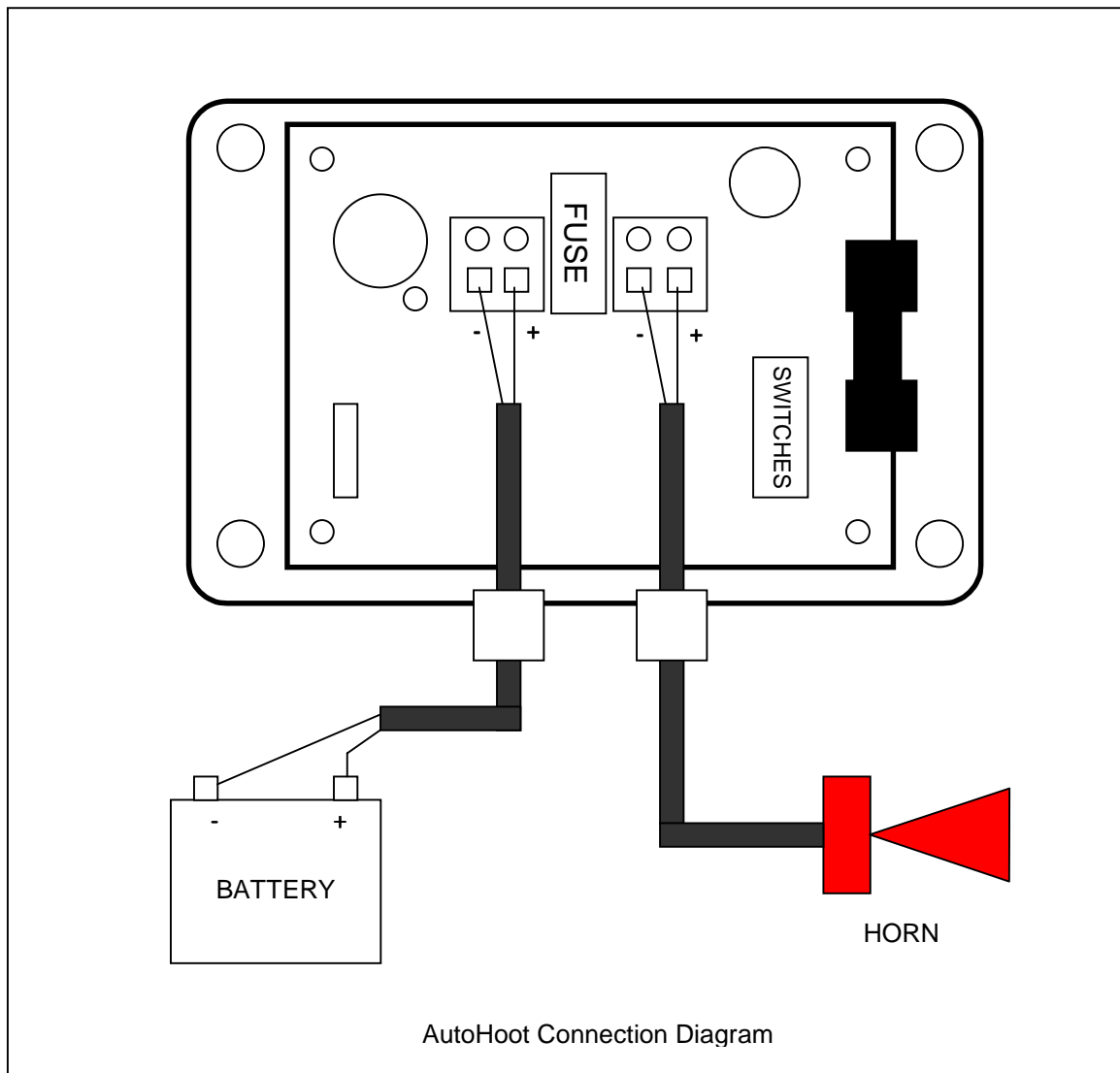



### 3. Quick set-up for RR26

If your preferred starting sequence is as given in ISAF racing rule 26 then this section is to save you having to read through the rest of this manual. The standard RR26 (5, 4, 1, 0) sequence has the warning signal at 5 minutes before the start. However as the rule gives the option of extending the warning time, AutoHoot provides a choice of 5, 6, 8 or 10 minutes for the warning signal. The diagram below gives details on how the eight small switches inside AutoHoot should be set.

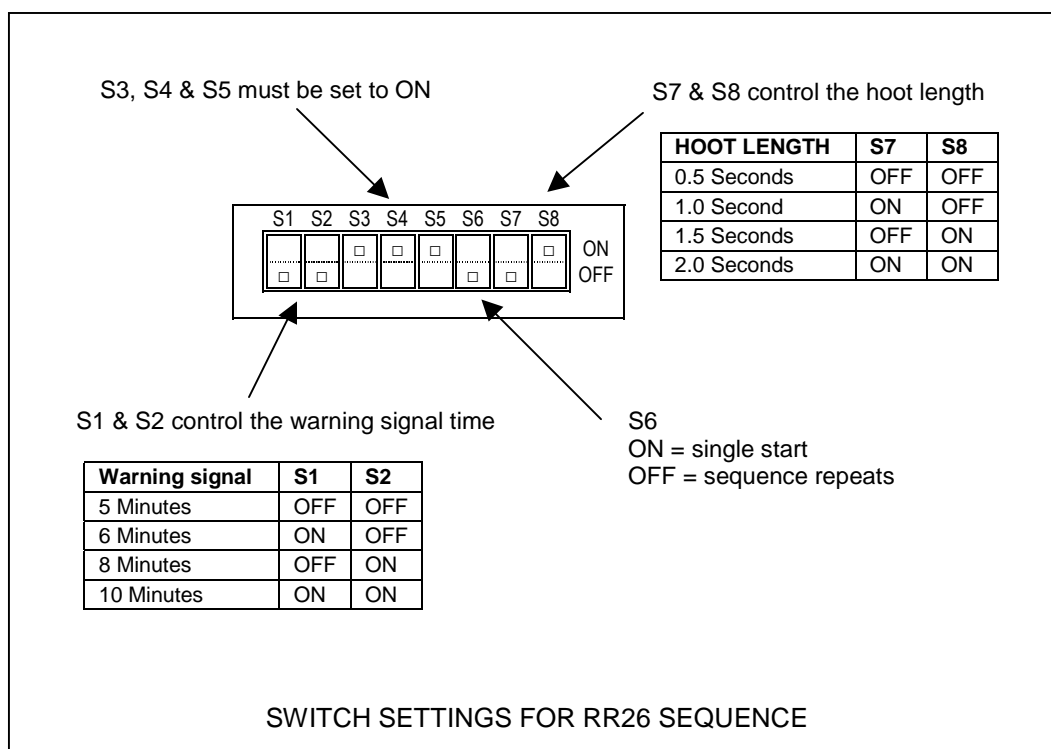



#### 4. Settings

There are a large number of different sequences in use for starting sailing races and internal switches are provided for adjusting the following:

- Sequence type
- Sequence length
- Repeat/single start
- Hoot length

There is also the option of 2 user programmable sequences. The following tables give a summary of switch settings:

##### Sequence type - S3, S4, S5

There is a choice of six predefined sequence types, plus two user programmable sequences. In the ISAF 2001 – 2004 rules the standard sequence is RR26 (5, 4, 1, 0) and has to a large extent made the two Olympic sequence options obsolete.

S3	S4	S5	Sequence type	Sequence letter
on	on	on	RR26	A
on	off	on	User programmable 1 & 2	B
off	off	on	Count-down	C
off	on	off	Match race	D
on	on	off	Old Olympic without overlap	E
on	off	off	Old Olympic with overlap	F
off	off	off	Old System 1 & 2	G

For convenience in these instructions the different sequence types have been allocated a letter.

##### Sequence length – S1, S2

For each of the predefined sequence types there are four options for sequence length selected using S1 and S2. When the user sequence type is selected these switches select which user sequence is used.

		SEQUENCE LENGTH							SEQUENCE REPEAT TIME						
S1	S2	A	B	C	D	E	F	G	A	B	C	D	E	F	G
off	off	5		5	10	5	6	10	5		5	5	5	5	5
on	off	6	User 1	4	8	4	5	8	6	User 1	4	4	4	4	4
off	on	8	User 2	3	6	3	4	6	8	User 2	3	3	3	3	3
on	on	10	User 1+2	2	4	6	3	4	10	User 1+2	2	2	6	2	2

##### Repeat/single start – S6

Switch S6 is used to make the sequence repeat or not. On some of the predefined sequences, where it is normal for the preparatory signal to also be the warning signal of the succeeding start, the repeat time is shorter than the sequence length, see above.

S6	Repeat/Single
off	Repeat
on	Single

##### Hoot length – S7, S8

There are four options for the hoot length set using switches S7 and S8

S7	S8	Hoot length
off	off	0.5 seconds
on	off	1 second
off	on	1.5 seconds
on	on	2 seconds



## 5. Start sequences

### RR26 – ISAF 2001-2004 Rules

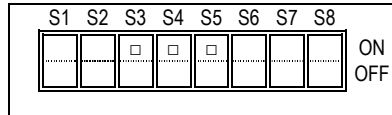

S1 off	S2 off	S1 on	S2 off	S1 off	S2 on	S1 on	S2 on	Signal	Flags	Sound
5		6		8		10		Warning	Class flag displayed	1 hoot
4		4		4		4		Preparatory	P, I, Z, Black flag or I and Z displayed	1 hoot
1		1		1		1		One minute	Preparatory flag lowered	1 hoot
0		0		0		0		Start	Class flag lowered	1 hoot

The 5, 4, 1, 0 is the standard sequence and if an extended warning time is used then this must be specified in the sailing instructions. If the sequence is to be shortened then the Olympic without overlap or a user programmable sequence can be used.

### User Programmable Sequences

Two programmable sequences are available. They are selected using the following switch settings:

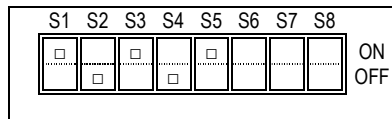

User Sequence 1

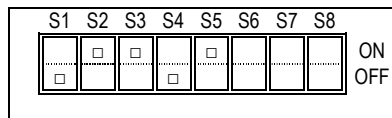

User Sequence 2

User Sequence can be set for a single sequence, S6 on or a repeating sequence S6 off. The two user sequences can be joined to form one long sequence

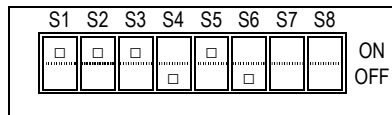

User Sequence 1 + 2

Note that when the two User Sequences are joined, S6 must be set to off for a repeating sequence.

Each user sequence can be up to 32 steps. Details of how the sequences are programmed can be found later in these instructions.



Count-down

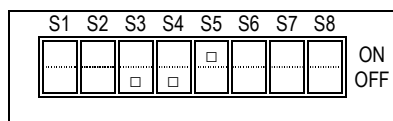

Count-down

The sequence length is set using S1 and S2 as given in the table in section 3. Sequence can be set for a single sequence, S6 on or a repeating sequence S6 off. The length of the long hoot is determined by the hoot length switch settings.

Time to start	Sound
5 minutes	5 long hoots
4 minutes	4 long hoots
3 minutes	3 long hoots
2 minutes	2 long hoots
1 minute 30 seconds	1 long hoot, 3 short hoots
1 minute	1 long hoot
30 seconds	3 short hoots
20 seconds	2 short hoots
10 seconds	1 short hoot
5 seconds	1 short hoot
4 seconds	1 short hoot
3 seconds	1 short hoot
2 seconds	1 short hoot
1 seconds	1 short hoot
0 seconds	1 long hoot

Match Race – ISAF RR Appendix C 3.1

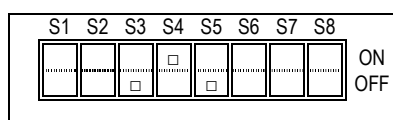

Match Race

Time to start	Signal	Flags	Sound
10 minutes	Attention	F flag displayed	1 hoot
6 minutes		F flag lowered	
5 minutes	Warning	Match numeral pennant displayed	1 hoot
4 minutes	Preparatory	P flag displayed	1 hoot
2 minutes	End of pre-start entry time	Blue or yellow flags if boats fail to comply with C4.2	1 hoot*
0 minutes	Start	Red flag displayed	1 hoot

\* hoot must be made manually if required.

The yellow and red LEDs and the internal buzzer give count-down warnings of 6, 5, 4, 2 and start signals.



Old Olympic without overlap

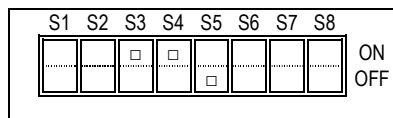

Old Olympic without overlap

This is similar to the RR26 sequence but switches S1 and S2 give options for shortening the sequence.

S1 off	S2 off	S1 on	S2 off	S1 off	S2 on	S1 on	S2 on	Signal	Flags	Sound
5		4		3		6		Warning	Class flag displayed	1 hoot
4		3		2		5		Preparatory	P, I, Z or Black flag displayed	1 hoot
1		1		1		1		One Minute	P, I, Z or Black flag lowered	1 hoot
0		0		0		0		Start	Class flag lowered	1 hoot

In successive starts the Start signal is the Warning signal for the next start.

Old Olympic with overlap

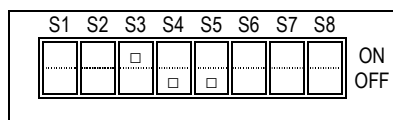

Old Olympic with overlap

S1 off	S2 off	S1 on	S2 off	S1 off	S2 on	S1 on	S2 on	Signal	Flags	Sound
6		5		4		3		Warning	Class flag displayed	1 hoot
5		4		3		2		Preparatory	P, I, Z or Black flag displayed	1 hoot
1		1		1		1		One Minute	P, I, Z or Black flag lowered	1 hoot
0		0		0		0		Start	Class flag lowered	1 hoot

In successive starts the One Minute signal is the Warning signal for the next start.

Old system 1 & 2 - ISAF 1997-2000 RR26.1 system 1 & 2

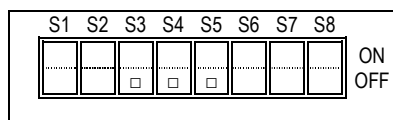

Old system 1 & 2

This sequence gives hoots at regular intervals and also the LEDs and buzzer give a count-down to one minute before the hoot to assist in lowering the signal in system 2. The sequence length can be adjusted using S1 and S2 as shown in this system 1 example

S1 off	S2 off	S1 on	S2 off	S1 off	S2 on	S1 on	S2 on	Signal	Flags	Sound
10		8		6		4		Warning	Class flag displayed	1 hoot
5		4		3		2		Preparatory	P flag displayed	1 hoot
0		0		0		0		Start	Class flag lowered	1 hoot



The flag signals for the old system 2 are:

Time to start	Signal	Flags	Sound
10 minutes	Warning	Yellow flag displayed	1 hoot
6 minutes		Yellow flag lowered	
5 minutes	Preparatory	Blue flag displayed	1 hoot
1 minute		Blue flag lowered	
0 minutes	Start	Red flag displayed	1 hoot

## 6. Programming User Sequences

- Using the User Sequence Programming Table given at the back of these instructions plan the required starting sequence. Enter the times to the start and calculate the times between hoots. Note the maximum time between hoots is 31 minutes 40 seconds. The all switches on setting is used as the first step in a user sequence command. These are outlined in section 7.
- Determine the switch settings for the times between hoots from the following tables and enter them on the User Sequence Programming Table. For the last step in the sequence all the switches should be set to off, to signify the end of the sequence.

TABLE 6.2

Seconds	S1	S2	S3	Seconds	S1	S2	S3
0	off	off	off	30	on	on	off
10	on	off	off	40	off	off	on
20	off	on	off	50	on	off	on

Minutes	S4	S5	S6	S7	S8	Minutes	S4	S5	S6	S7	S8
0	off	off	off	off	off	16	off	off	off	off	on
1	on	off	off	off	off	17	on	off	off	off	on
2	off	on	off	off	off	18	off	on	off	off	on
3	on	on	off	off	off	19	on	on	off	off	on
4	off	off	on	off	off	20	off	off	on	off	on
5	on	off	on	off	off	21	on	off	on	off	on
6	off	on	on	off	off	22	off	on	on	off	on
7	on	on	on	off	off	23	on	on	on	off	on
8	off	off	off	on	off	24	off	off	off	on	on
9	on	off	off	on	off	25	on	off	off	on	on
10	off	on	off	on	off	26	off	on	off	on	on
11	on	on	off	on	off	27	on	on	off	on	on
12	off	off	on	on	off	28	off	off	on	on	on
13	on	off	on	on	off	29	on	off	on	on	on
14	off	on	on	on	off	30	off	on	on	on	on
15	on	on	on	on	off	31	on	on	on	on	on

- To enter the sequence into AutoHoot first the user sequence 1 or user sequence 2 must be selected with the switches as follows.

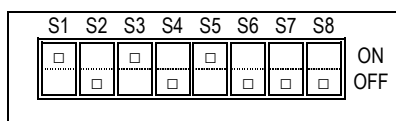

User Sequence 1

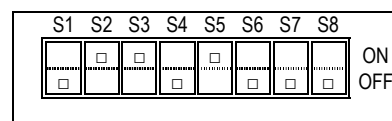

User Sequence 2



4. Hold pressed the red Hoot switch and switch the Auto switch ON, OFF and ON. The horn will stop sounding. Release the Hoot switch. The buzzer will make 2 beeps and the red LED come on. AutoHoot is now in programme mode. If it fails to enter programming mode switch the Black Auto switch ON and then OFF without the Red Hoot switched pressed to clear the previous attempt at entering programming mode and then try again.
5. Set the switches to the time to the next hoot as previously determined.
6. Press the red Hoot switch to enter the time. The buzzer will beep twice to confirm the entry. Release the Hoot switch.
7. If more hoots are required go to step 4 or if it is the end of the sequence set all the switches off and press the red hoot switch. A series of beeps and the yellow LED coming on will indicate that the sequence is being programmed into AutoHoot's memory. Release the hoot switch and after the beeps stop switch off the Auto switch. The sequence will remain in AutoHoot's memory until reprogrammed even if the power is removed.
8. To use the programmed user sequence set switches as follows:

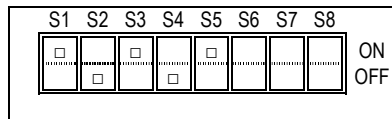

User Sequence 1

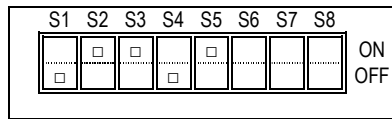

User Sequence 2

The two user sequences can be joined to form one long sequence

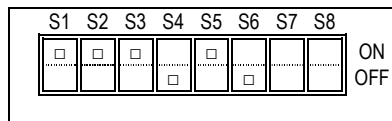

User Sequence 1 + 2

## 7. User sequence commands

In addition to specifying the time between hoots there are a number of commands available. These all require two sequence steps. The first being to set all the switches to on. In the following only the second step of each command is shown.

### Delay 0 to 15 seconds

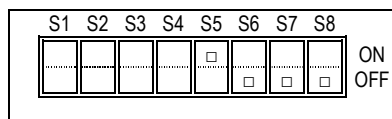

S1 to S4 are set to the required delay time, in seconds, as given in table 7.1



Delay 0 to 15 seconds and hoot

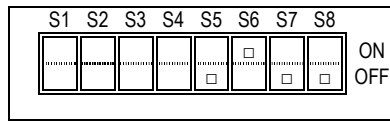

S1 to S4 are set to the required delay time as given in table 7.1

Delay 30 minutes

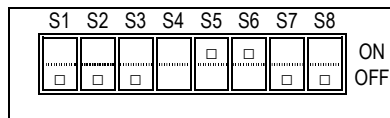

This command gives a 30 minute delay without the LEDs or beeper giving a warning of the end of the period. If S4 is set to on then the three hour time out will not apply at the end of the sequence.

Hoot control

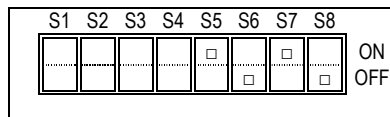

- S1 on – next sequence hoot silenced.
- S2 on – all sequence hoots silenced
- S3 on – short hoots
- S4 on – warning beeps silenced

These settings do not affect the manually operated hoot made by pressing the red switch.

Set counter

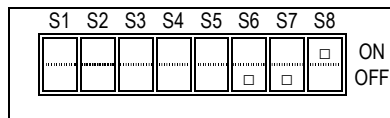

S1 to S5 are set to the required count as given in table 7.1

Jump if counter not zero and decrement counter

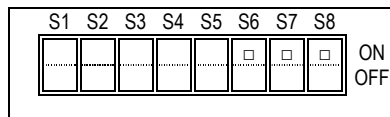

S1 to S5 are set to the number of the step (see table 7.1) to be jumped to if the counter is not zero. The program steps should be numbered with the first step as zero. Note that the counter must be set to the number of times that the jump is to be done. If this instruction is at the end of a loop then this will be one less than the number of times the steps within the loop are to be done.



Set outputs

This command controls three signals that can be made available on the circuit board. If required these could be used to control lights or an external timer. If fitted OUT1 is available on the miniature terminal block just above the ribbon cable connector. The two terminals are 0v and OUT1. 0v is nearest the ribbon cable connector. A 2mm blade screwdriver is required to do up the contacts. The OUT1 output has a 330 ohm resistor in series to provide some protection. The other two outputs are direct from AutoHoots processor and as such have no over voltage or current protection. Please contact Richard Paul Russell Limited before using these signals. Damage caused to AutoHoot due to the use of these signals is not covered by the Guarantee.

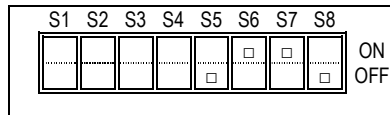

- S1 on – set OUT1 high (+5v)
- S1 off – set OUT1 low (0v)
- S2 on – set OUT2 high (+5v)
- S2 off – set OUT2 low (0v)
- S3 on – set OUT3 high (+5v)
- S3 off – set OUT3 low (0v)

At the end of the sequence or when the Auto switch is set to off these outputs go to the low state.

Switch settings for values in user sequence commands

Table 7.1

Value	S1	S2	S3	S4	S5	Value	S1	S2	S3	S4	S5
0	off	off	off	off	off	16	off	off	off	off	on
1	on	off	off	off	off	17	on	off	off	off	on
2	off	on	off	off	off	18	off	on	off	off	on
3	on	on	off	off	off	19	on	on	off	off	on
4	off	off	on	off	off	20	off	off	on	off	on
5	on	off	on	off	off	21	on	off	on	off	on
6	off	on	on	off	off	22	off	on	on	off	on
7	on	on	on	off	off	23	on	on	on	off	on
8	off	off	off	on	off	24	off	off	off	on	on
9	on	off	off	on	off	25	on	off	off	on	on
10	off	on	off	on	off	26	off	on	off	on	on
11	on	on	off	on	off	27	on	on	off	on	on
12	off	off	on	on	off	28	off	off	on	on	on
13	on	off	on	on	off	29	on	off	on	on	on
14	off	on	on	on	off	30	off	on	on	on	on
15	on	on	on	on	off	31	on	on	on	on	on



Command summary

Command	S1	S2	S3	S4	S5	S6	S7	S8
Delay 0 to 15 seconds	on	on	on	on	on	on	on	on
	*	*	*	*	on	off	off	off
Delay 0 to 15 seconds and hoot	on	on	on	on	on	on	on	on
	*	*	*	*	off	on	off	off
Delay 30 minutes	on	on	on	on	on	on	on	on
	off	off	off	*	on	on	off	off
Hoot control	on	on	on	on	on	on	on	on
	*	*	*	*	on	off	on	off
Set outputs	on	on	on	on	on	on	on	on
	*	*	*	*	off	on	on	off
Set counter	on	on	on	on	on	on	on	on
	*	*	*	*	*	off	off	on
Jump if not zero and decrement counter	on	on	on	on	on	on	on	on
	*	*	*	*	*	on	on	on
End of sequence	off	off	off	off	off	off	off	off
Delay and hoot	s	s	s	m	m	m	m	m

\* See command description for switch setting  
s, m see table 6.2



### 8. User Sequence Example

A club runs a pursuit race and requires the following signals

09:50 Warning signal

09:55 Preparatory signal

10:00 First start

Then starts at 1-minute intervals until 10:20

11:15 Finish (signified by 2 sound signals)

First set the switches for the required user sequence. In this example we will use sequence 1

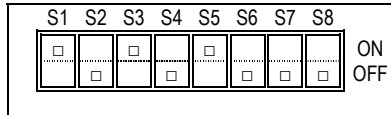

User Sequence 1

Enter programming mode by holding the red hoot switch pressed and switch the Black Auto switch ON, OFF and back ON. The following steps are then entered by pressing the hoot switch after the switches have been set for each step.

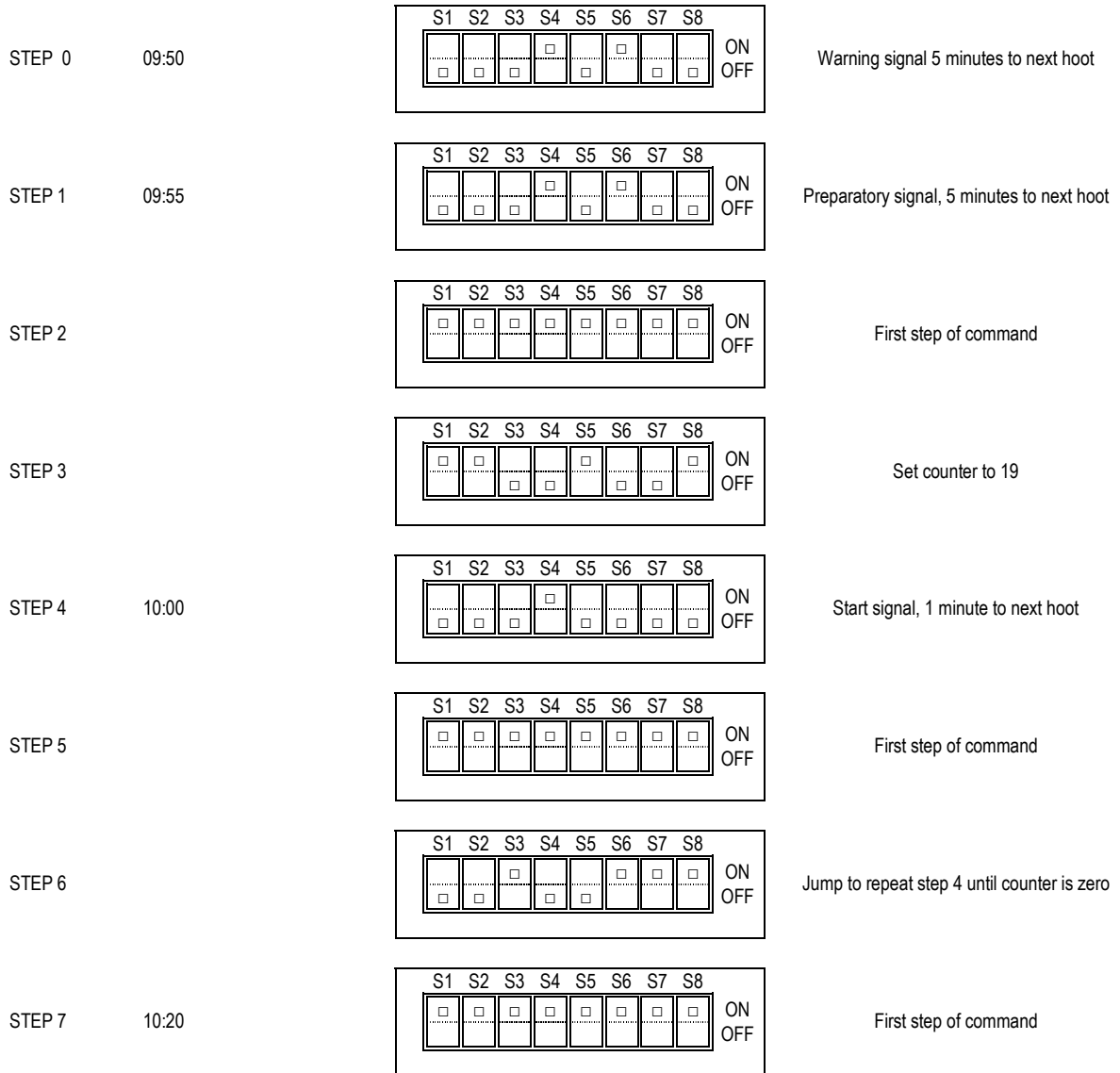



STEP 8			Delay 30 minutes.
STEP 9	10:50		25 minutes to first finish hoot
STEP 10			First step of command
STEP 11	11:15		Delay 2 second to second hoot
STEP 12			End of sequence

When the hoot switch is pressed to enter the end of sequence instruction there will be a series of beeps (one for each step) to indicate that sequence is being entered in to AutoHoot's memory. After the beeps have stopped the Auto switch should be set to off. To use the sequence the internal switches should be set as follows

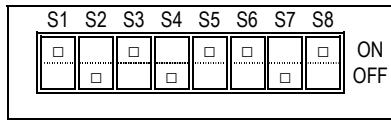

S6 has been set to on as the sequence does not need to be repeated and S7 and S8 have been set for 1.5 seconds hoots.

## 9. Power indication

The green LED indicates when power is being supplied. AutoHoot monitors the supply voltage and the green LED will flash every 2 seconds if the voltage is less than about 8.5 volts. If AutoHoot is left on for more than 3 hours without the hoot switch being pressed or the auto switch being switched on, then the green LED will switch off and only give a short flash every 15 seconds, so power consumption is reduced to a minimum.

If power is interrupted during a start sequence then the buzzer will sound for 15 seconds and the red and green LED's switch on. A postponement should be signalled and the sequence restarted by switching the auto switch off and on again.



## 10. AutoHoot specification

### Physical

Size	80mm x 120mm x 74mm (excluding cable entries)
Weight	410g
Sealing	IP65
Case material	High impact polycarbonate
Temperature	Operating range -20C to 70C
Mounting holes	4 diameter 4mm, centres 50.2mm x 108.2mm
Enclosure lid fastening	4 stainless steel spring loaded quick release screws

### Electrical

Supply voltage	9V to 27V
Supply current (excluding horn)	15mA at 12V
Max Horn switch current at 12V	20A
EMC	CE marked

### Settings

Sequence length	Selectable depending on the sequence type
RR26 warning signal	5, 6, 8 or 10 minutes
Sequence type	RR26, Match Race, Count Down, Old System 1 & 2, Old Olympic with and without overlap or Use Programmable
Hoot time	0.5, 1, 1.5 or 2 seconds

### Operation

Start sequence on/off	Large rotary switch on front
Manual hoot	Large push button on front
Warnings	LEDs - Power, 90s (30s), 60s Internal buzzer
Settings	Internal switches

### Miscellaneous

Timing	Quartz crystal oscillator
Horn switch	Solid state high side switch

### Guarantee

AutoHoot is guaranteed against faulty materials and manufacture for one year from the date of purchase. The guarantee does not apply to units which have been subjected to misuse, negligence, accident, improper maintenance or application or which have been repaired or altered without the prior consent of Richard Paul Russell Limited.



USER SEQUENCE PROGRAMMING TABLE												
EVENT												
USER SEQUENCE NUMBER _____								SHEET _____ of _____				
Step no.	Time of step	Time to next Hoot	S1	S2	S3	S4	S5	S6	S7	S8		NOTES
											ON	
											OFF	
											ON	
											OFF	
											ON	
											OFF	
											ON	
											OFF	
											ON	
											OFF	
											ON	
											OFF	
											ON	
											OFF	
											ON	
											OFF	
											ON	
											OFF	
											ON	
											OFF	
											ON	
											OFF	

Please photocopy if more sheets are required.